



SERVICE MANUAL

TU-X501 TU-X501L DIGITAL SYNTHESIZER TUNER



CAUTION

1. Parts identified by the \triangle symbol on the schematic diagram and the parts list are critical for safety. Use only replacement parts that have critical characteristics recommended by the manufacturer.
2. Make leakage-current or resistance measurements to determine that exposed parts are acceptably insulated from the supply circuit before returning the appliance to the customer.

•SPECIFICATIONS

FM Section

Tuning range..... 87.5 to 108 MHz
Usable sensitivity

Mono IHF 10.8 dBf (0.95 μ V/75 Ω)

50 dB quieting sensitivity

Mono 16.0 dBf

Stereo 36.0 dBf

Signal to noise ratio at 85 dBf

Mono 86 dB

Stereo 80 dB

Distortion at 65 dBf

Mono less than 0.05% at 1,000 Hz

Stereo less than 0.06% at 1,000 Hz

Alternate channel selectivity (at 400 kHz)

WIDE 50 dB

NARROW 75 dB

Stereo separation 50 dB at 1,000 Hz

Frequency response 20 to 15,000 Hz
+0.5 dB, -0.5 dB

Antenna input impedance

..... 75 ohms unbalanced

AM (MW) Section

Tuning range..... 530 to 1,600 kHz

Usable sensitivity 48 dB/m (251 μ V/m)

Signal to noise ratio 50 dB (80 dB/m)

Image response ratio 45 dB at 1,000 kHz

LW Section <TU-X501L only>

Tuning range..... 153 to 281 kHz

Usable sensitivity 60 dB/m at 210 kHz

Others

Output voltage and impedance

..... 0.775 V

Power requirements 120/220/240V

50/60 Hz

For U.S.A. and Canada

..... 120V (60 Hz)

Power consumption 10 Watts

Dimensions 448 mm (17-11/16")W

80 mm (3-3/16")H

292 mm (11-1/2")D

Weight 3.5 kg (7.7 lbs) net

4.8 kg (10.6 lbs) packed

* Design and specifications subject to changes without notice for improvements.

* Due to local laws and regulations, this unit sold in some areas are not equipped with variable voltage selectors

NOTE

1. The symbols, UL, CSA, SA, BS, UK, EU, AS, SEV, SS and XX <EXPORT> on the parts list and the schematic diagram mean followings respectively.

- UL..... Manufactured for U.S.A market.
(Underwriters Laboratories approved model.)
- CSA..... Manufactured for Canadian market.
- SA..... Manufactured for South African market.
- BS, UK..... Manufactured for United Kingdom market.
- EU..... Manufactured for European market.
- AS..... Manufactured for Australian market.
- SEV..... Manufactured for Swiss market.
- SS..... Manufactured for Saudi Arabia market.
- XX <EXPORT> .. Standard Version.
- NON MARK..... Common Parts.

2. Some printed circuit boards are not supplied assembled. To separate these in this service manual, the stock numbers are not indicated for these boards. However, stock numbers for individual parts are indicated.

3. Since some capacitors and resistors are omitted from parts lists in this service manual, refer to the Common Parts List for capacitors and resistors, which was issued on June 1987.

4. Abbreviations in this service manual are as follows.

•Abbreviations List

- C.R. : Carbon Resistor
- S.R. : Solid Resistor
- Ce.R. : Cement Resistor
- M.R. : Metal Film Resistor
- F.R. : Fusing Resistor
- N.I.R. : Non-Inflammable Resistor
- A.R. : Array Resistor
- C.C. : Ceramic Capacitor
- C.T. : Ceramic Capacitor, Temperature Compensation
- E.C. : Electrolytic Capacitor
- E.L. : Low Leak Electrolytic Capacitor
- E.B. : Bi-Polar Electrolytic Capacitor
- E.B.L. : Low Leak Bi-Polar Electrolytic Capacitor
- Ta.C. : Tantalum Capacitor
- F.C. : Film Capacitor
- M.P. : Metalized Paper Capacitor
- P.C. : Polystyrene Capacitor
- G.C. : Gimmic Capacitor
- A.C. : Array Capacitor
- V.R. : Variable Resistor
- S.V.R. : Semi Variable Resistor
- SW. : Switch
- Chip R. : Chip Resistor
- Chip C. : Chip Capacitor

1. PACKING LIST

Parts No.	Stock No.	Description
1	27306700	Vinyl Bag
2	27394100	Styrofoam Packing
3	27493800	TU-X501 Carton Case
	27493700	TU-X501L Carton Case

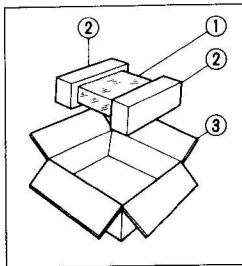

2. ACCESSORY LIST

Stock No.	Description
48730700	Antenna Plug
46051700	FM Antenna
46548700	AM Loop Antenna
38103300	PJP Cord
49029000	TU-X501/X501L Operating Instruction (*E•F•S)
49029100	TU-X501/X501L Operating Instruction (*G•I•Sw)

***Note**

- E•F•S:** English•French and Spanish Version
- G•I•Sw:** German•Italian and Swedish Version

3. BLOCK DIAGRAM

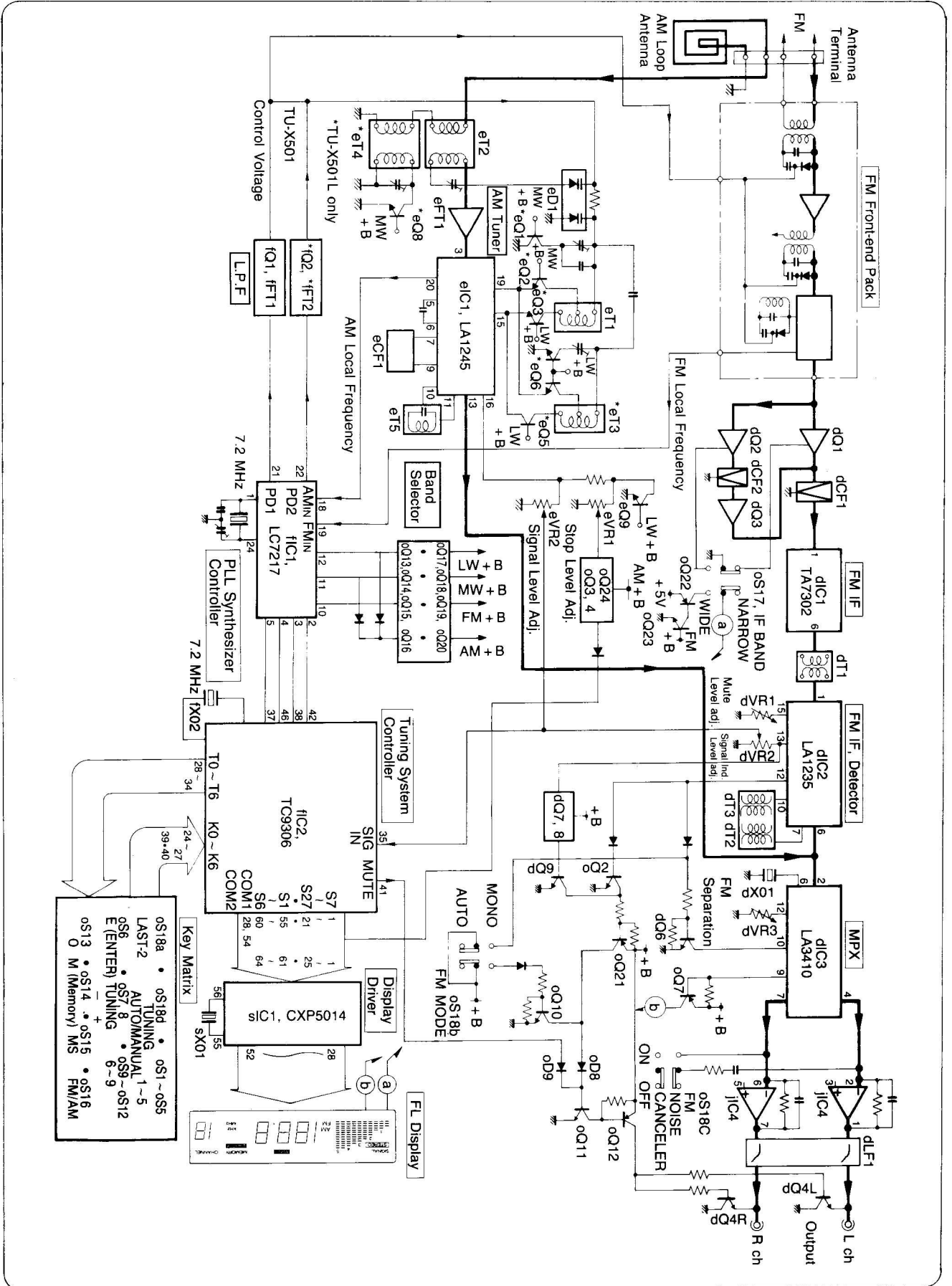

Key Matrix

0S18a	•	0S18d	•	0S1~0S5
LAST-2	•	AUTOMANUAL 1~5		
0S6	•	0S7 8	•	0S9~0S12
E(ENTER) TUNING	•	6~9		
0S13	•	0S14	•	0S15
0		M (Memory) MS	•	0S16
		FM/AM		

4. ADJUSTMENTS

4-1. FM Adjustment (See Top View on Page 9)

- Note:** 1. FM/AM Switch..... FM
 2. FM MODE (BAND) Switch..... MONO (Steps 1, 2, 3, 4); AUTO (Step 5)
 3. IF BAND Switch WIDE
 4. FM NOISE CANCELER OFF
 5. Connect as shown Fig. 4-1.

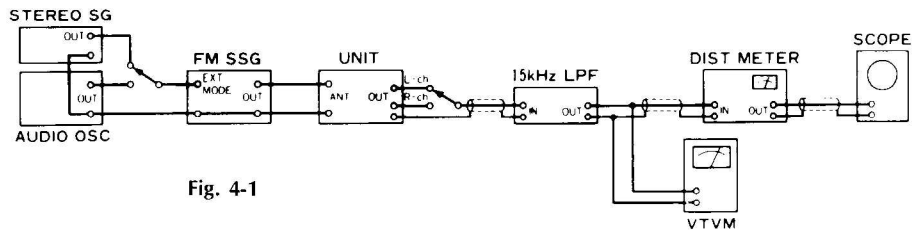

Fig. 4-1

STEP	SUBJECT	FEED SIGNAL		MEASURE OUTPUT	ADJUST	ADJUST FOR	REMARKS
		FROM	TO				
1.	Reference Frequency Adj.	No Input	—	Between Point (A) (Pin 24 of f1C1) and GND (F-5740), Frequency Counter	fTC1 (F-5740)	7.200000MHz ± 100Hz	
2.	Discriminator Coil Adj.	①	No Input	Between Point (B) (TP1) and Point (C) (TP2), (Across the dR38, F-5740) DC Volt Meter	dT1 (F-5740)	DC 0V ± 10mV	•Repeat procedures as stated in subject ① & ②
		②	98MHz ANT Input, 65dBf (59.8dB), 1kHz (100% MOD.), FM SSG	FM ANT Terminal	FL Display (Reception Frequency)	MANUAL TUNING, TUNING (-, +) Switch	
3	Muting Level Adj.	98MHz ANT Input, 22dBf (16.8dB), 1kHz (100% MOD.), FM SSG	FM ANT Terminal	FL Display (Reception Frequency)	MANUAL TUNING, TUNING (-, +) Switch	98.00MHz	
				Output L or R ch, Dist Meter	dT3 (F-5740)	Min. THD	
4	Signal Indicator Level Adj.	98MHz ANT Input, 18dBf (12.8dB), 1kHz (100% MOD.), FM SSG	FM ANT Terminal	FL Display (Reception Frequency)	MANUAL TUNING, TUNING (-, +) Switch	98.00MHz	lighting
				Signal Indicator (FL Display)	dVR2 (F-5740)	Make only one signal indicator lighting.	
5	Stereo Separation Adj.	98MHz ANT Input, 65dBf (59.8dB), FM SSG, Pilot 19kHz (9% MOD.), L MODE 1kHz+Pilot (100% MOD.), STEREO SG	FM ANT Terminal	OUTPUT L ch, VTVM & Oscilloscope	—	Read the indication on VTVM	•Confirm R→L ch
				OUTPUT R ch, VTVM & Oscilloscope	dVR3 (F-5740)	-37dB from the indication above.	

◆ADJUSTMENT FOR FM

There are two kind in indication of FM SSG output attenuator.

1. Attenuator with marking of 75Ω open open indication type.
 2. Attenuator with marking of 75Ω load or close load or close indication type.
- FM SG output level in this FM adjustment are described as open indication type.

To feed FM signal, a dummy antenna circuit as Fig. 4-2 must be connected between FM SG output and ANT terminal (300Ω) of the unit.

Fig. 4-2

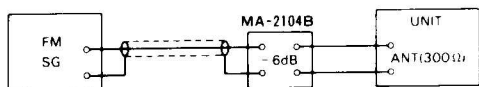

- The following table shows relations among FM SG attenuator indication (dB), available power ratio (dBf) and antenna terminal voltage (dB/μV) in each indication type.

	FM SG Attenuator Indication	Available Power Ratio	Antenna Terminal Voltage
Open indication type	0 dB 66 dB	-0.8 dBf 65.2 dBf	-6 dB/μV 60 dB/μV
Load or close indication type	0 dB 60 dB	5.2 dBf 65.2 dBf	0 dB/μV 60 dB/μV

4-2. AM (MW, LW) Adjustment (See Top View on Page 9)

- Note: 1. FM/AM Switch..... AM (TU-X501),
 BAND Switch..... MW (TU-X501L) 2. Connect AM loop antenna to AM antenna terminal.
 3. Connect as shown Fig. 4-3.

Fig. 4-3

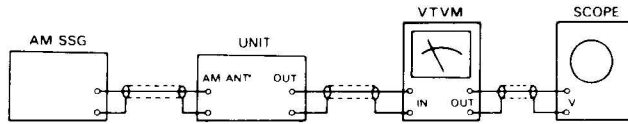
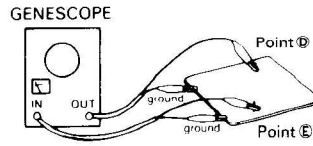

Fig. 4-4



1) AM IF and MW (AM) Tuning Adjustment

STEP	SUBJECT	FEED SIGNAL		MEASURE OUTPUT	ADJUST	ADJUST FOR	REMARKS
		FROM	TO				
1.	IF Coil Adj.	Output 60dB, Genescope	Between Point ㉑ (eC8, F-5740) and GND	Between Point ㉑ (eR19, F-5740) and GND	eCF1, eT5 (F-5740)	Max. Waveform	
2.	531kHz (or 530kHz) Tuning Adj.	No Input	—	FL Display (Reception Frequency)	MANUAL TUNING, TUNING (—, +) Switch	531kHz (or 530kHz)	•Repeat procedures as stated in STEP 2 and 3.
				Between Point ㉑ (eR1, F-5740) and GND, DC Volt Meter	eT1 (F-5740)	DC 1.0V ± 0.2V	
3.	1602kHz (or 1610kHz) Tuning Adj.	No Input	—	FL Display (Reception Frequency)	MANUAL TUNING, TUNING (—, +) Switch	1602kHz (or 1610kHz)	
				Between Point ㉑ (eR1, F-5740) and GND, DC Volt Meter	eTC1 (F-5740)	8.0V ± 0.2V	
4.	603kHz (or 600kHz) RF Adj.	603kHz (or 600kHz) ANT Input, 30dB, 400Hz (30% MOD.,) AM SSG	AM ANT Terminal	FL Display (Reception Frequency)	MANUAL TUNING, TUNING (—, +) Switch	603kHz (or 600kHz)	•Repeat procedures as stated in STEP 4 and 5.
				Output L or R ch, VTVM & Oscilloscope	eT2 (F-5740)	Max. Output	
5.	1404kHz (or 1400kHz) RF Adj.	1404kHz (or 1400kHz) ANT Input, 30dB, 400Hz (30% MOD.,) AM SSG	AM ANT Terminal	FL Display (Reception Frequency)	MANUAL TUNING, TUNING (—, +) Switch	1404kHz (or 1400kHz)	
				Output L or R ch, VTVM & Oscilloscope	eTC3 (TU-X501) eTC4 (a) (TU-X501L) (F-5740)	Max. Output	
6.	Signal Indicator Level Adj. (TU-X501)	999kHz (or 1000kHz) ANT Input, 70dB, 400Hz (30% MOD.,) AM SSG	AM ANT Terminal	FL Display (Reception Frequency)	MANUAL TUNING, TUNING (—, +) Switch	999kHz (or 1000kHz)	
				Signal Indicator (FL Display)	eVR2 (F-5740)	Make 5 signal indicators lighting	
7.	Auto Stop Level Adj. (TU-X501)	999kHz (or 1000kHz) ANT Input, 47dB, 400Hz (30% MOD.,) AM SSG	AM ANT Terminal	FL Display (Reception Frequency)	MANUAL TUNING, TUNING (—, +) Switch	999kHz (or 1000kHz)	•Indication voltage on the DC Volt Meter change from "L" to "H" level.
				Between Point ㉑ (oD7, F-5740) and GND, DC Volt Meter	eVR1 (F-5740)	DC 1.7V ~ 2.0V	
8.	Auto Stop Level Adj. (TU-X501L)	999kHz ANT Input, 60dB, 400Hz (30% MOD.,) AM SSG	AM ANT Terminal	FL Display (Reception Frequency)	MANUAL TUNING, TUNING (—, +) Switch	999kHz	
				Between Point ㉑ (oD4, F-5740) and GND, DC Volt Meter	eVR1 (F-5740)	DC 1.7V	

2) LW Tuning Adjustment < TU-X501L only >

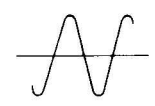
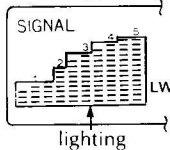
STEP	SUBJECT	FEED SIGNAL		MEASURE OUTPUT	ADJUST	ADJUST FOR	REMARKS
		FROM	TO				
1.	153kHz Tuning Adj.	No Input	—	FL Display (Reception Frequency)	MANUAL TUNING, TUNING (—, +) Switch	153kHz	•Repeat procedures as stated in STEP 1 and 2.
				Between Point(⊕) (eR1, F-5740) and GND, DC Volt Meter	eT3 (F-5740)	1.0V ± 0.2V	
2.	281kHz Tuning Adj.	No Input	—	FL Display (Reception Frequency)	MANUAL TUNING, TUNING (—, +) Switch	281kHz	
				Between Point(⊕) (eR1, F-5740) and GND, DC Volt Meter	eTC2 (F-5740)	5.4V ± 0.2V	
3.	170kHz RF Adj.	170kHz ANT Input, 30dB, 400Hz (30% MOD.), AM SSG	ANTENNA Terminal	FL Display (Reception Frequency)	MANUAL TUNING, TUNING (—, +) Switch	170kHz	•Repeat procedures as stated in STEP 3 and 4.
				Output L or R ch, VTVM & Oscilloscope	eT4 (F-5740)	MAX. Output	
4.	260kHz RF Adj.	260kHz ANT Input, 30dB, 400Hz (30% MOD.), AM SSG	Same as above	FL Display (Reception Frequency)	MANUAL TUNING, TUNING (—, +) Switch	260kHz	
				Output L or R ch, VTVM & Oscilloscope	eTC4(⊕) (F-5740)	MAX. Output	
5.	Signal Indicator Level Adj.	210kHz ANT Input, 80dB, 400Hz (30% MOD.), AM SSG	Same as above	FL Display (Reception Frequency)	MANUAL TUNING, TUNING (—, +) Switch	210kHz	
				Signal Indicator (FL Display)	eVR2 (F-5740)	Make 5 signal indicators lighting	

5. DESCRIPTION OF FV-172G, FL DISPLAY

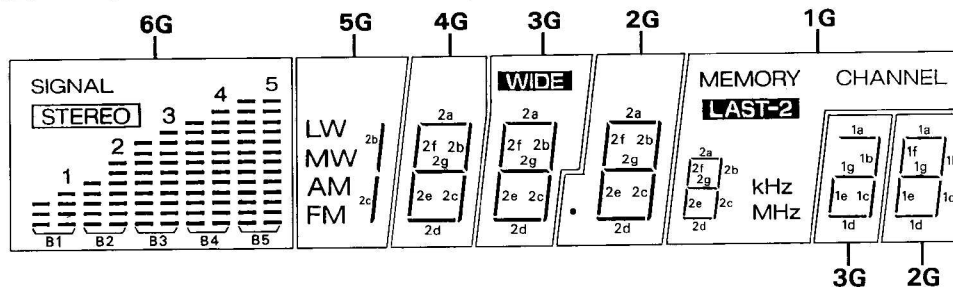

Pin Connection

PIN NO.	1	2	3	4	5	6	7	8	9	10	11	12	13	14	15	16	17	18	19	20	21	22	23	24	25	26	27	28	29	30	31	32	33	34	35	36	37	38	39	40	41	42		
CONNECTION	F	F	N	p	l	m	k	N	p	o	n	j	i	N	p	h	d	e	c	N	p	g	f	b	a	N	N	N	N	N	N	N	N	7	6	5	N	4	3	2	1	N	F	F

Grid Anode	6G	5G	4G	3G	2G	1G
a	STEREO	—	—	1a	1a	MEMORY
b	—	—	—	1b	1b	LAST-2
c	B3	—	—	1c	1c	kHz
d	B1	FM	—	1d	1d	MHz
e	B2	—	—	1e	1e	—
f	B5	—	—	—	1f	—
g	B4	LW	—	1g	1g	—
h	—	—	2a	2a	2a	—
i	—	2b	2b	2b	2b	—
j	—	2c	2c	2c	2c	2b e

Grid Anode	6G	5G	4G	3G	2G	1G
k	—	—	2d	2d	2d	2a c d f
l	—	—	2e	2e	2e	2g
m	—	—	2f	2f	2f	—
n	—	—	2g	2g	2g	—
o	—	—	—	—	•	—
p	—	MW	—	—	—	—
q	—	AM	—	—	—	—
r	SIGNAL 12345	—	—	—	—	CHANNEL
s	—	—	—	WIDE	—	—

6. PARTS LOCATION ON BOARD

6-1. F-5740 Main Board Component Side

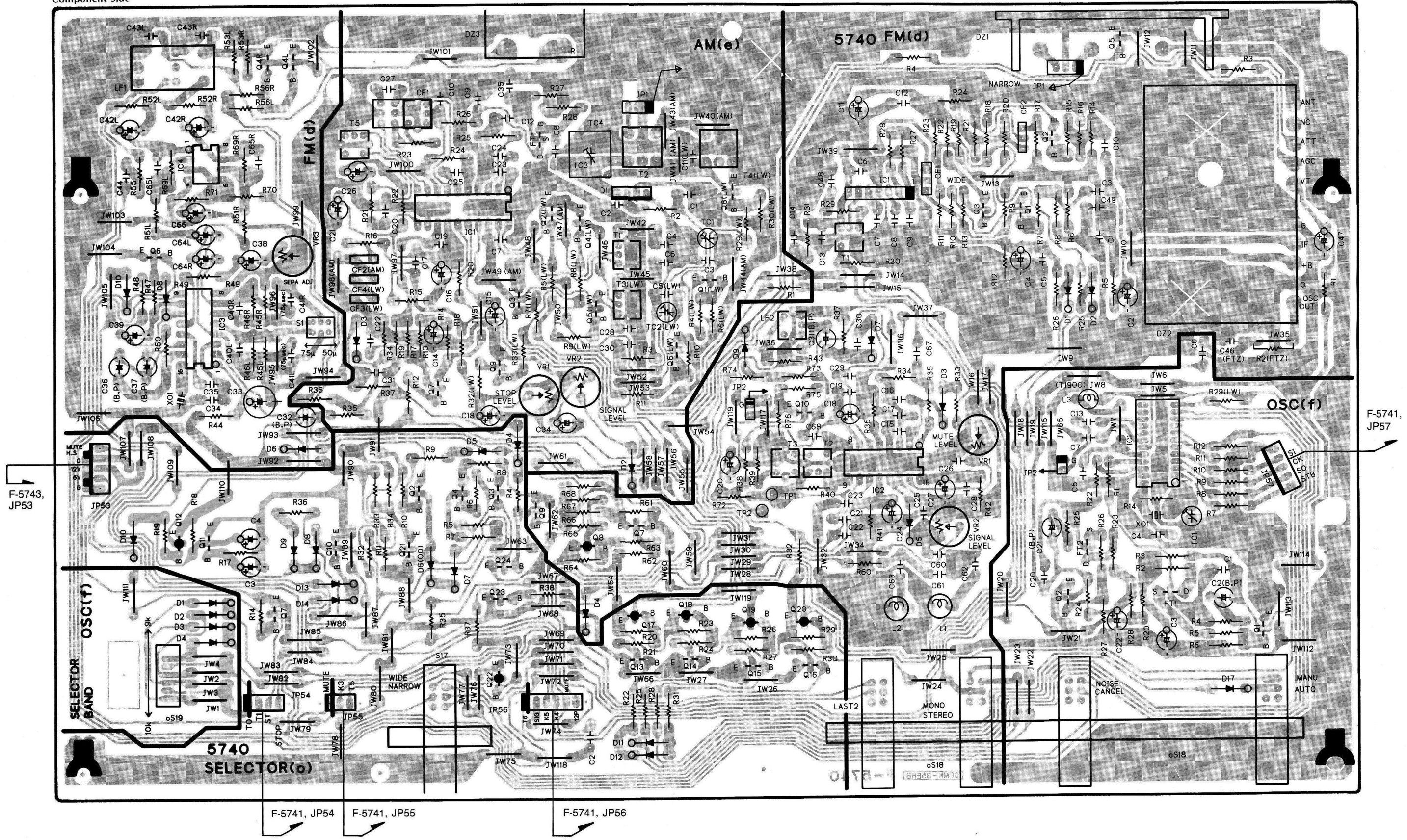

6-2. F-5741 Tuner Control and Indicator Board

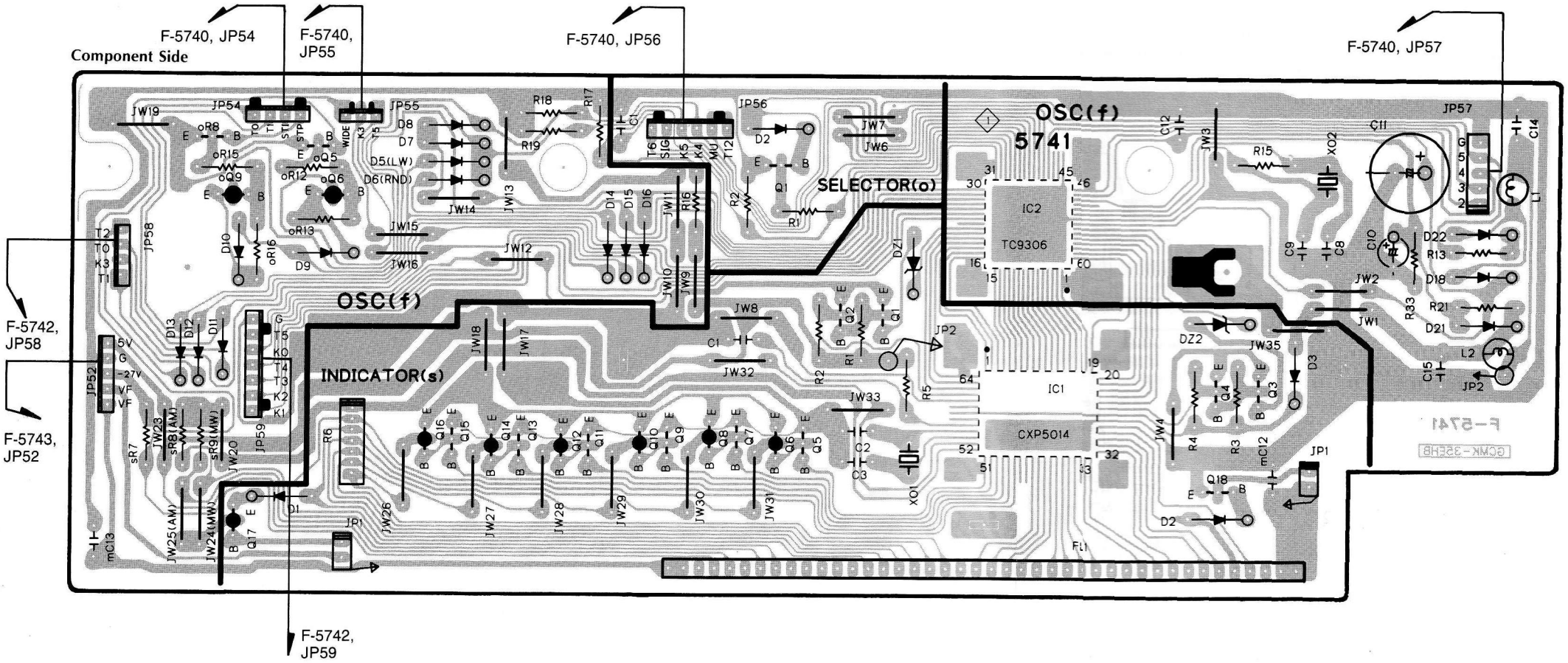

7. PARTS LIST OF BOARD

7-1. F-5740 Main Board
 (Stock No.01051401: TU-X501-XX-SS,
 01051405: TU-X501-EU
 01051805: TU-X501L)

Parts No.	Stock No.	Description
dZ2	48989200	FM.Frontend Pack
• Transistor		
dQ1-3	46393201	2SC2786
dQ4	46540801	2SC2878
	or 46604301	2SC3327
dQ6	46719900	DTC124ES
dQ7	46393201	2SC2786
dQ8	46367201	2SA1048
	or 46392001	2SA1175
dQ9	46367101	2SC2603
	or 46367301	2SC2458
	or 46391901	2SC2785
dQ10	46393201	2SC2786
• IC		
dIC1	03605900	TA7302P
dIC2	48347500	LA1235
dIC3	48491000	LA3410A
dIC4	07208900	NJM4558D-X
	or 46580100	M5218P
dXO1	48128400	KBR-457HS Ceramic OSC Element
• Diode		
dD1-4	03117600	1S2473T77
	or 46086000	1S1588TP-3
dD5	48731600	SV-04YS (Varistor)
dD6-10	03117600	1S2473T77
	or 46086000	1S1588TP-3
△dR5	46228200	22Ω 1/2W N.I.R
△dR31	46228200	22Ω 1/2W N.I.R
△dR32	46228200	22Ω 1/2W N.I.R
dC31	48108500	10μF 50V E.B.
dC32	48108500	10μF 50V E.B.
dC36	48107900	0.47μF 50V E.B.
dC37	48108100	1μF 50V E.B.
dCF1	48983000	SFE10.7ML Ceramic Filter
dCF2	48064800	SFE10.7MS3G Ceramic Filter
dLF1	46579200	Low Pass Filter
dL1	46091100	8.2mH Inductor
dL2	46091100	8.2mH Inductor
dT1	46369500	FM IF Coil
dT2	48347600	FM IF Coil
dT3	48347700	FM IF Coil
dVR1	46634300	10kΩ S.V.R., FM muting level adj.
dVR2	46634700	47kΩ S.V.R., FM signal ind. level adj.
dVR3	46635100	220kΩ S.V.R., FM separation adj.
dS1	07251100	Slide SW., 75μS/50μS (TU-X501-XX-SS)
dZ3	46725200	2P Pin Jack Terminal, OUTPUT
dZ1	48864900	2P Antenna Terminal (TU-X501-XX-SS)
	48865000	2P Antenna Terminal (TU-X501-EU, TU-X501L)

6-3. F-5742 FM/AM Selector, Preset and Tuning Switch Board

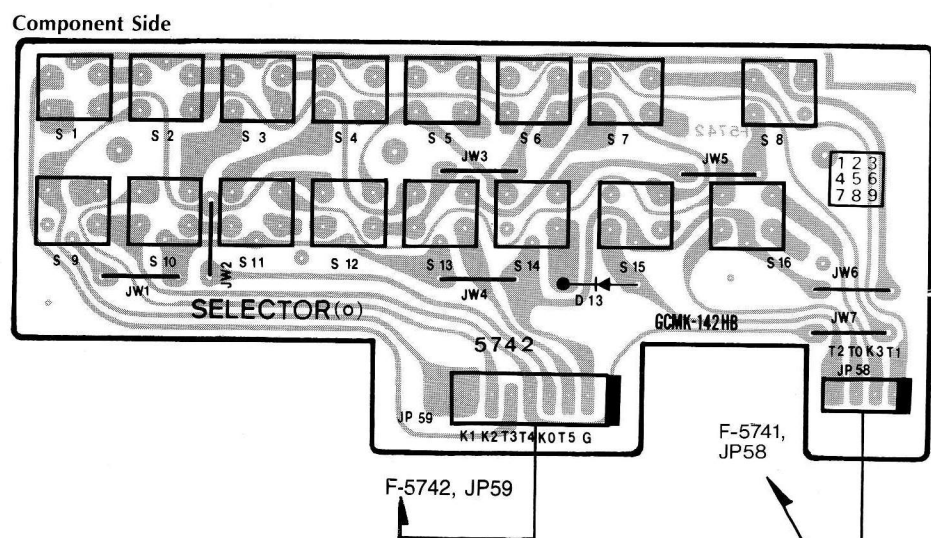

6-4. F-5743 Power Supply Board

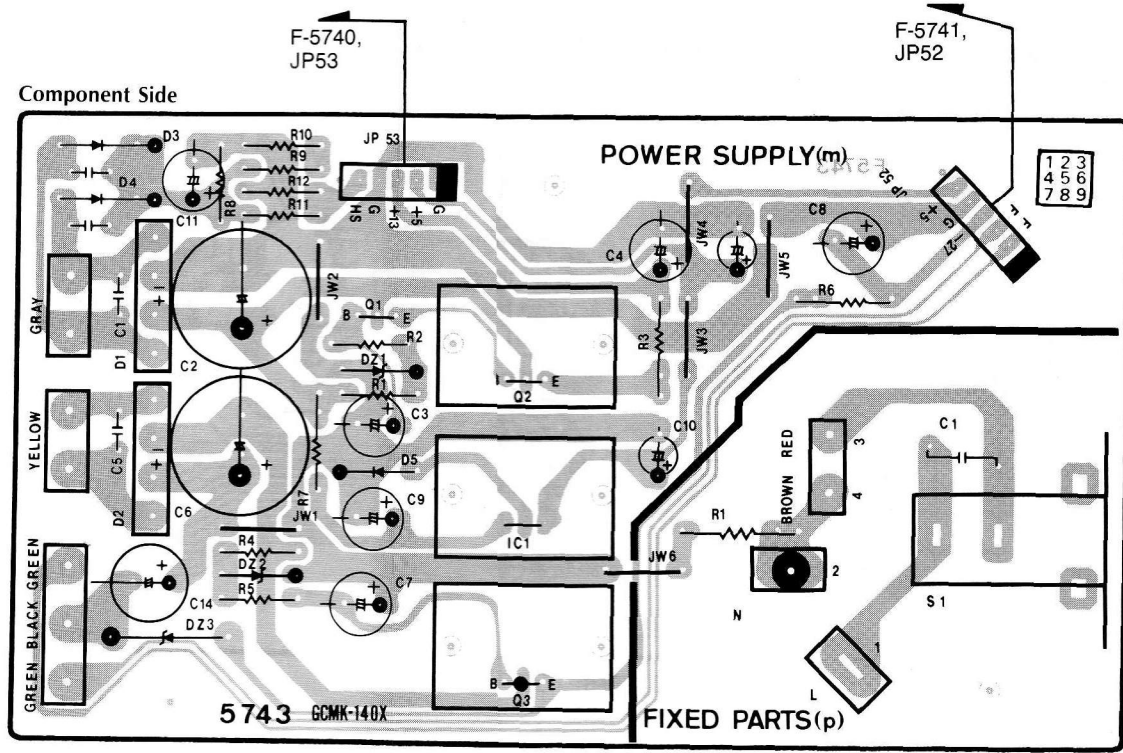

Parts No.	Stock No.	Description
•Transistor		
eQ1 ~ 6	46540801	2SC2878 (TU-X501L)
eQ7	46367101	2SC2603
	or 46367301	2SC2458
	or 46391901	2SC2785
eQ8	46540801	2SC2878 (TU-X501L)
eQ9	46367101	2SC2603 (TU-X501L)
	or 46367301	2SC2458 (TU-X501L)
	or 46391901	2SC2785 (TU-X501L)
•FET		
eFT1	46393000	2SK192A-Y
	or 46393001	2SK192A-GR
•IC		
eIC1	07237200	LA1245
•Diode		
eD1	46146300	KV1236Z2 (Variable Capacitance)
eD2	03117600	1S2473T77
	or 46086000	1S1588TP-3
eD3	03117600	1S2473T77
	or 46086000	1S1588TP-3
△eR20	46228200	22Ω 1/2W N.I.R
eTC1	46095600	20pF Trimmer Capacitor
	or 46162800	20pF Trimmer Capacitor
	or 46437400	20pF Trimmer Capacitor
eTC2	46095700	30pF Trimmer Capacitor (TU-X501L)
eTC3	46095600	20pF Trimmer Capacitor (TU-X501)
	or 46162800	20pF Trimmer Capacitor (TU-X501)
	or 46437400	20pF Trimmer Capacitor (TU-X501)
eTC4	46370700	16pF Trimmer Capacitor (TU-X501L)
eCF1	07254000	SFL450G3 Ceramic Filter
eCF2	46578100	BFU450C10N Ceramic Filter
eCF3, 4	46578100	BFU450C10N Ceramic Filter (TU-X501L)
eT1	46394700	AM OSC Coil
eT2	46394600	AM ANT Coil
eT3	46548800	LW OSC Coil (TU-X501L)
eT4	46397900	LW RF Coil (TU-X501L)
eT5	46369600	AM IF Coil
eVR1	46634700	47kΩ S.V.R., AM auto stop level adj.
eVR2	46634700	47kΩ S.V.R., AM signal ind. level adj.
•Transistor		
fQ1	46367101	2SC2603
	or 46367301	2SC2458
	or 46391901	2SC2785
fQ2	46367301	2SC2458 (TU-X501L)
	or 46367101	2SC2603 (TU-X501L)
	or 46391901	2SC2785 (TU-X501L)
•FET		
fFT1	46643501	2SK163-K2
	or 46643502	2SK163-L1
	or 46643601	2SK117-Y
	or 46643602	2SK117-GR
fFT2	46643501	2SK163-K2 (TU-X501L)
	or 46643502	2SK163-L1 (TU-X501L)
	or 46643601	2SK117-Y (TU-X501L)
	or 46643602	2SK117-GR (TU-X501L)

Parts No.	Stock No.	Description
•IC		
fIC1	48840300	LC7217
fXO1	07237700	NR-18 Quartz Crystal
•Diode		
fD1, 2	03117600	1S2473T77 (TU-X501•XX•SS)
	or 46086000	1S1588TP-3 (TU-X501•XX•SS)
fD3, 4	03117600	1S2473T77 (TU-X501•EU, TU-X501L)
	or 46086000	1S1588TP-3 (TU-X501•EU, TU-X501L)
fD17	03117600	1S2473T77
	or 46086000	1S1588TP-3
fC2	48103500	2.2μF 50V E.B.
fTC1	46095600	20pF Trimmer Capacitor
fL3	46204500	10μH Inductor
•Transistor		
oQ2 ~ 4	46367101	2SC2603
	or 46367301	2SC2458
	or 46391901	2SC2785
oQ7	46719800	DTA124ES
oQ10	46719900	DTC124ES
oQ11	46367101	2SC2603
	or 46367301	2SC2458
	or 46391901	2SC2785
oQ12	46367201	2SA1048
	or 46392001	2SA1175
oQ13	46391901	2SC2785 (TU-X501L)
oQ14	46367101	2SC2603 (TU-X501L)
	or 46367301	2SC2458
	or 46391901	2SC2785
oQ15	46367101	2SC2603
	or 46367301	2SC2458
	or 46391901	2SC2785
oQ16	46367101	2SC2603
	or 46367301	2SC2458
	or 46391901	2SC2785
oQ17, 18	46392001	2SA1175 (TU-X501L)
	or 46367201	2SA1048 (TU-X501L)
oQ19	46367201	2SA1048
	or 46392001	2SA1175
oQ20	46367201	2SA1048
	or 46392001	2SA1175
oQ21	46719800	DTA124ES
oQ22	46367001	2SA1115
oQ23	46367101	2SC2603
oQ24	46367101	2SC2603
•Diode		
oD4	03117600	1S2473T77
	or 46086000	1S1588TP-3
oD5	03117600	1S2473T77
	or 46086000	1S1588TP-3
oD7	03117600	1S2473T77
	or 46086000	1S1588TP-3
oD8 ~ 14	03117600	1S2473T77
	or 46086000	1S1588TP-3
oS17	46365300	Push SW., FM IF WIDE/NARROW
oS18	48846800	Push SW., LAST-2•FM NOISE CANCELER•FM MODE•TUNING
oS19	46177200	Slide SW., 10k/9kHz (TU-X501•XX•SS)

7-2. F-5741 Tuner Control and Indicator Board

(Stock No.01051501: TU-X501•XX•SS
01051505: TU-X501•EU
01051905: TU-X501L)

Parts No.	Stock No.	Description
•IC		
fIC2	48840200	TC9306-007
fXO2	07237700	NR-18 Quartz Crystal
•Diode		
fD5	03117600	1S2473T77 (TU-X501L)
	or 46086000	1S1588TP-3
fD7 ~ 16	03117600	1S2473T77
	or 46086000	1S1588TP-3
fD18	03117600	1S2473T77
	or 46086000	1S1588TP-3
fD21 ~ 23	03117600	1S2473T77
	or 46086000	1S1588TP-3
fC11	48798300	8200μF 5.5V E.C.
fL1	46204500	10μH Inductor
fL2	46204500	10μH Inductor
•Transistor		
oQ1	46719900	DTC124ES
oQ5	46719900	DTC124ES
oQ6	46367201	2SA1048
	or 46392001	2SA1175
oQ8	46719900	DTC124ES
oQ9	46367201	2SA1048
	or 46392001	2SA1175
•Diode		
oD2	03117600	1S2473T77
	or 46086000	1S1588TP-3
oD3	03117600	1S2473T77
	or 46086000	1S1588TP-3
•Transistor		
sQ1 ~ 5	48217800	DTC114ES
sQ6	48229600	DTA114ES
sQ7	48217800	DTC114ES
sQ8	48229600	DTA114ES
sQ9	48217800	DTC114ES
sQ10	48229600	DTA114ES
sQ11	48217800	DTC114ES
sQ12	48229600	DTA114ES
sQ13	48217800	DTC114ES
sQ14	48229600	DTA114ES
sQ15	48217800	DTC114ES
sQ16	48229600	DTA114ES
sQ17	48229600	DTA114ES
sQ18	48217800	DTC114ES
•IC		
sIC1	48904000	CXP5014
sXO1	48343900	CSA3.60 Ceramic OSC Element
•Diode		
sD1	03117600	1S2473T77
	or 46086000	1S1588TP-3
sD2	03117600	1S2473T77
	or 46086000	1S1588TP-3
•Zener Diode		
sDZ1	46823200	RD3.0E-B1
sDZ2	46823200	RD3.0E-B1
sFL1	48903900	FL. Display Tube FV172G
sR6	48771100	100kΩX6 A.R.

7-3. F-5742 FM/AM Selector, Preset and Tuning Switch Board

Parts No.	Stock No.	Description
•Diode		
oD1	03117600	1S2473T77
	or 46086000	1S1588TP-3
oS1	48306900	Push SW., 1 (preset)
oS2	48306900	Push SW., 2 (preset)
oS3	48306900	Push SW., 3 (preset)
oS4	48306900	Push SW., 4 (preset)
oS5	48306900	Push SW., 5 (preset)
oS6	48306900	Push SW., ENTER
oS7	48306900	Push SW., TUNING —
oS8	48306900	Push SW., TUNING +
oS9	48306900	Push SW., 6 (preset)
oS10	48306900	Push SW., 7 (preset)
oS11	48306900	Push SW., 8 (preset)
oS12	48306900	Push SW., 9 (preset)
oS13	48306900	Push SW., 10 (preset)
oS14	48306900	Push SW., MEMORY
oS15	48306900	Push SW., MEMORY SCAN
oS16	48306900	Push SW., FM/AM (BAND)

7-4. F-5743 Power Supply Board

(Stock No.01051701: TU-X501
01052105: TU-X501L)

Parts No.	Stock No.	Description
•Transistor		
△mQ1	46367101	2SC2603
△	or 46367301	2SC2458
△	or 46391901	2SC2785
△mQ2	03083901	2SD313HP
△mQ3	48063301	2SB507
•IC		
△mIC1	48599500	AN78N05
•Diode		
△mD1	07193300	UB-152LFF
△mD2	03117000	RB152-LFF
△mD3	03117600	1S2473T77
△	or 46086000	1S1588TP-3
△mD4	03117600	1S2473T77
△	or 46086000	1S1588TP-3
△mD5	03117600	1S2473T77
△	or 46086000	1S1588TP-3
•Zener Diode		
mDZ1	46114500	05Z15-Y
mDZ2	46116000	05Z24-Y
mDZ3	03168500	RD5.1F
mDZ4	46114500	05Z15-Y
△mR7	46249800	270Ω 1W N.I.R
△pC1	46371700	4700pF 400V C.C.
△pS1	46360300	Push SW., POWER

8. OTHER PARTS

8-1. Front View



Parts List <Front View>

Parts No.	Stock No.	Description	Parts No.	Stock No.	Description
1	27427410	Front Panel Ass'y (TU-X501)	1-15	27417700	TUNING+Push Knob
	27427510	Front Panel Ass'y (TU-X501L)	2	27394020	Bonnet
1-1	27419300	1•Push Knob	3	48903900	FL Display Tube
1-2	27419400	2•Push Knob	4	48306900	Push SW., Preset (1~10) etc.,
1-3	27419500	3•Push Knob	5	27377000	Dress Side Panel R
1-4	27419600	4•Push Knob	6	48846800	Push SW. (4-key), TUNING+FM NOISE CANCELER FM MODE+LAST-2
1-5	27419700	5•Push Knob	7	27388700	Push Knob, TUNING+FM NOISE CANCELER FM MODE+LAST-2
1-6	27419800	6•Push Knob	8	46365300	Push SW., TUNING+FM MODE
1-7	27419900	7•Push Knob	9	27470500	Leg
1-8	27420000	8•Push Knob	△10	46360300	Push SW., POWER
1-9	27420100	9•Push Knob	11	27420500	POWER Knob
1-10	27420200	10•Push Knob	12	47920800	Joint, POWER SW.
1-11	27420300	MS•Push Knob, MEMORY SCAN	13	27376900	Dress Side Panel L
1-12	27419100	E•Push Knob, ENTER	14	48836500	M5x14 Special Screw
1-13	27419200	M•Push Knob, MEMORY			
1-14	27417800	FM/AM•Push Knob (TU-X501)			
	27417900	BAND•Push Knob (TU-X501L)			

8-2. Top View

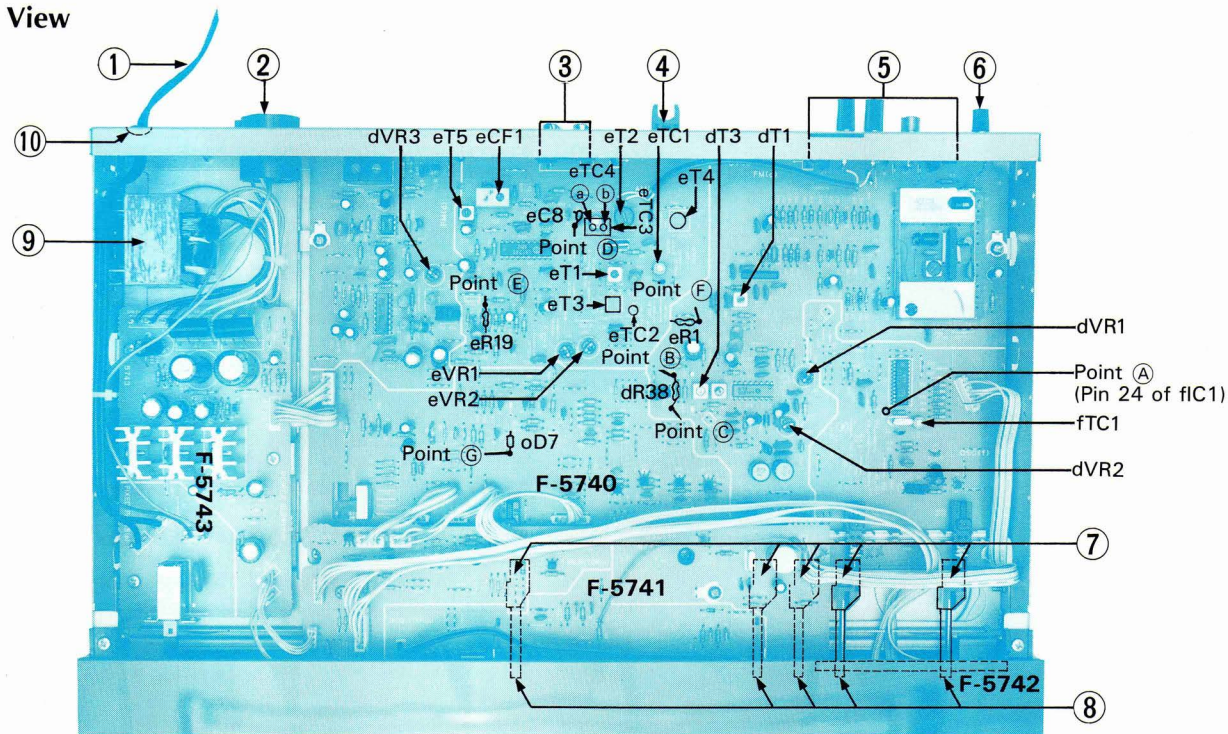

Parts List <Top View>

Parts No.	Stock No.	Description
△ 1	38005700	Power Supply Cord (TU-X501•XX)
△	48837700	Power Supply Cord (TU-X501•SS)
△	38004500	Power Supply Cord (TU-X501•EU, TU-X501L)
△ 2	48175200	Voltage Selector (TU-X501•XX•SS)
△	07204700	Slide SW., (TU-X501•EU, TU-X501L)
3	46725200	2P Pin Jack Terminal, OUTPUT
4	07193200	AM Antenna Holder
5	48864900	Antenna Terminal

Parts No.	Stock No.	Description
6	22301510	GND Terminal
7	27388600	Joint, Push SW.
8	27414900	Rod, Push SW.
△ 9	15029709	Power Transformer (TU-X501•XX•SS)
△	15029705	Power Transformer (TU-X501•EU, TU-X501L)
10	39106000	Strain Relief (TU-X501•XX)
	48913500	Strain Relief (TU-X501•EU•SS, TU-X501L)

9. INTERIOR BLOCK DIAGRAM OF ICs

•LA3410A (MPX)

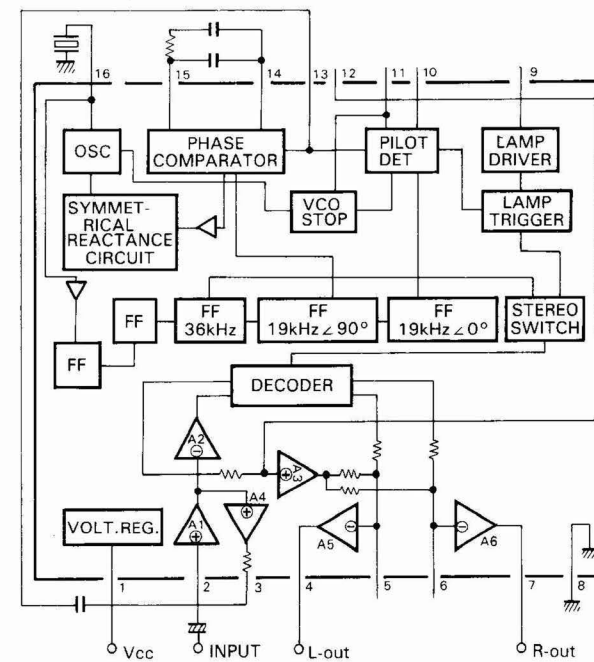

•LC7217 (PLL Synthesizer)

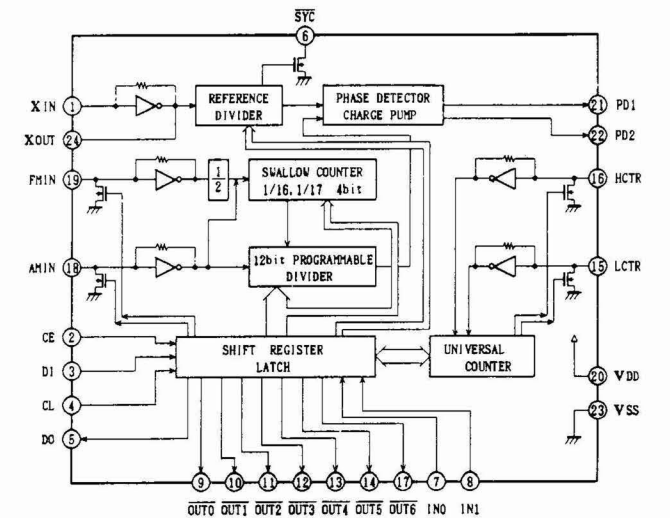

•LA1235 (IF Amp., Detector, Muting and Tuning Meter Drive)

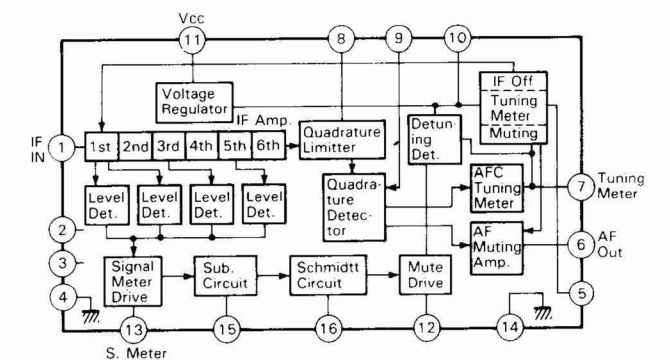

•TA7302P (FM IF Amp.)

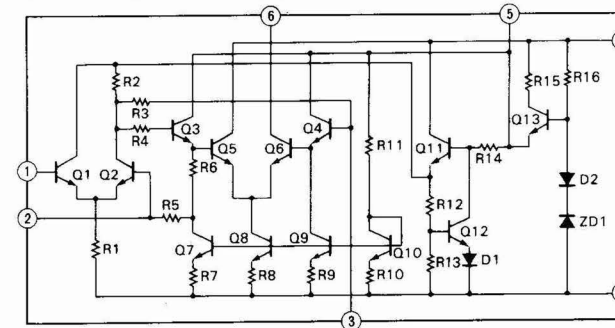

10. SCHEMATIC DIAGRAM 10-1. Main Section

* Design and specifications subject to change without notice for improvement.
 * La présentation et les spécifications sont susceptibles d'être modifiées sans préavis par suites d'améliorations éventuelles.
 * Änderungen, die dem technischen Fortschritt dienen, bleiben vorbehalten.

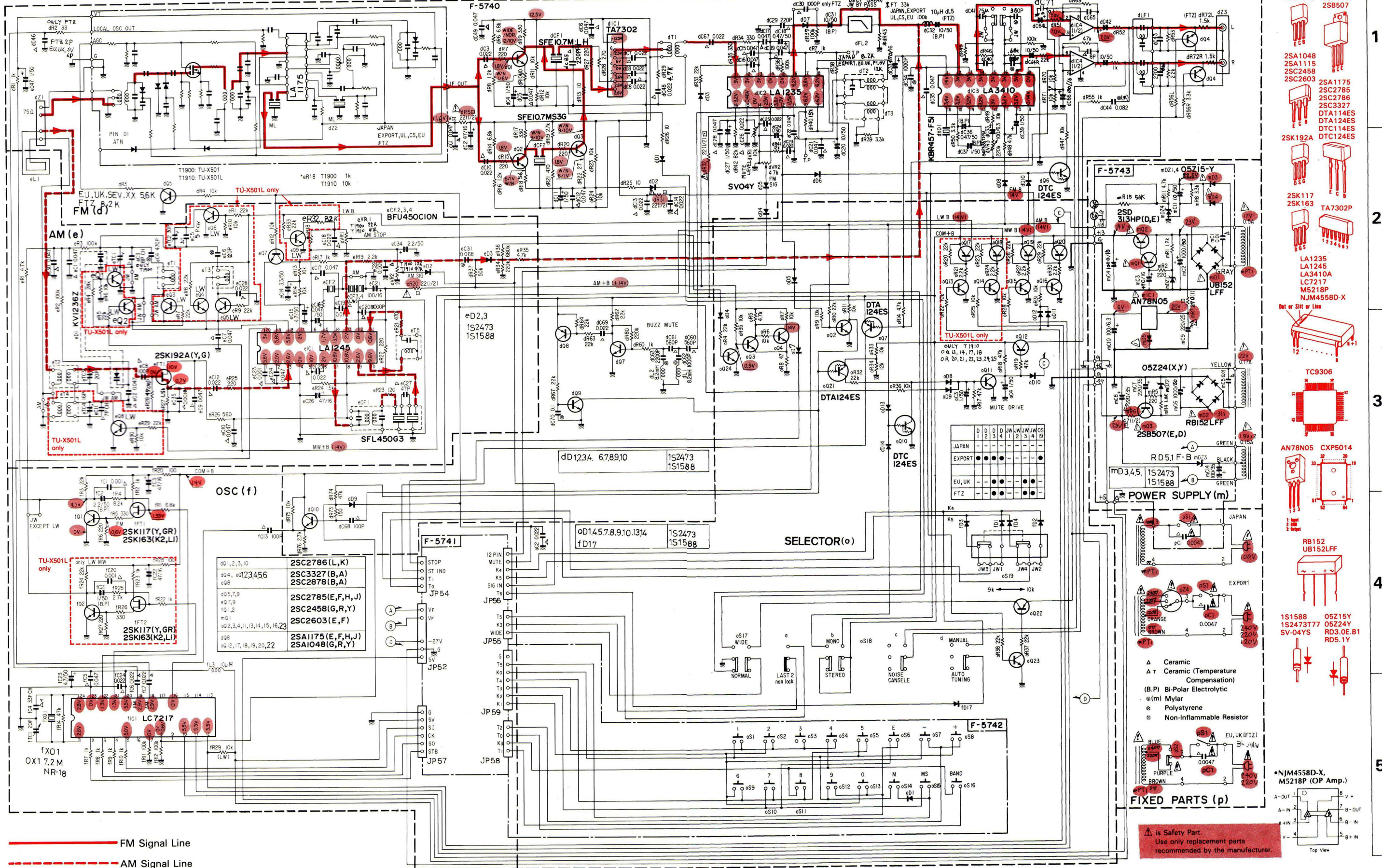

— FM Signal Line
 - - - AM Signal Line

- 1 2SC2878 2SA1313 2SB507
- 2 2SA1048 2SA1115 2SC2458 2SC2603
- 3 2SA1175 2SC2785 2SC2786 2SC3327 DTA1144ES DTA1244ES DTC1144ES
- 4 2SK192A DTC1244ES
- 5 2SK117 2SK163 TA7302P
- LA1235 LA1245 LA3410A LC7217 M5218P NJM4558D-X
- Det or Silt or Line
- TC9306
- AN78N05 CXP5014
- RB152 UB152LFF
- 1S1588 05Z15Y 1S2473T77 05Z24Y SV-04YS RD3.0E.B1 RD5.1Y
- *NJM4558D-X, M5218P (OP Amp.)

FIXED PARTS (p)

▲ is Safety Part.
 Use only replacement parts recommended by the manufacturer.

▲ Ceramic
 ▲ T Ceramic (Temperature Compensation)
 (B,P) Bi-Polar Electrolytic
 (m) Mylar
 ● Polystyrene
 □ Non-Inflammable Resistor

EU, UK (FTZ)
 BLUE 240V 0.0047
 PURPLE 220V 0.0047
 BROWN 220V 0.0047

A-OUT 1 B V+
 A-IN 2 7 B-OUT
 A+IN 3 8 B-IN
 V- 4 5 B+IN
 Top View

10-2. Tuner Control and Indicator Section

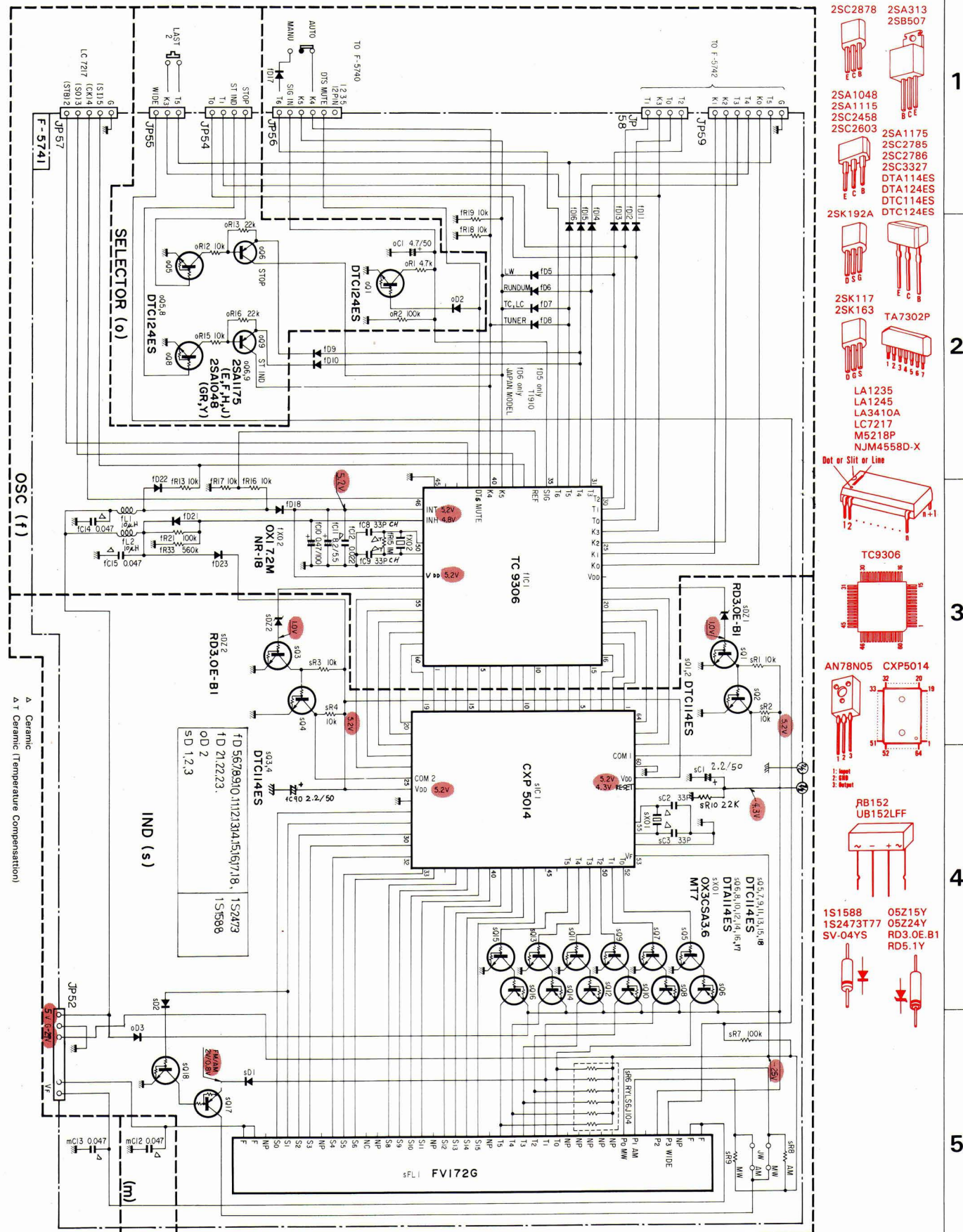

* Design and specifications subject to change without notice for improvement.
 * La présentation et les spécifications sont susceptibles d'être modifiées sans préavis par suites d'améliorations éventuelles.
 * Änderungen, die dem technischen Fortschritt dienen, bleiben vorbehalten.

11. TERMINAL FUNCTION OF ICs, TC9306 and CX5014

•TC9306-007 < Digital Tuning system Control >

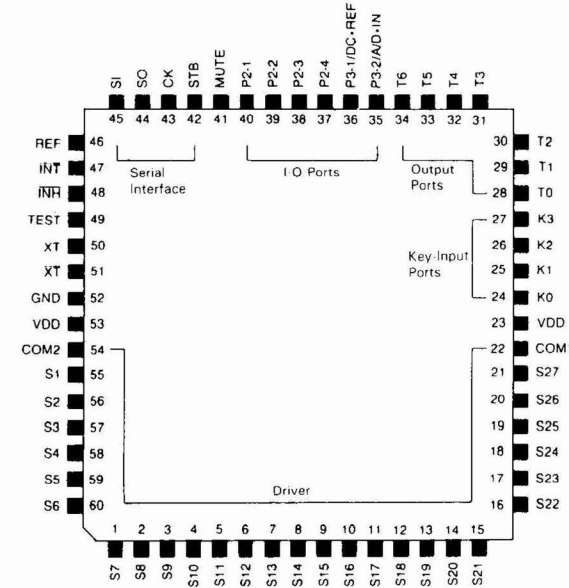

♦ TC9306-007 < Terminal Function >

Pin No.	Pin Name	Function
22	COM1	Terminal for outputting common signals to FL display driver IC. Note: The output is fixed at "L" level automatically when the system is reset or executing CK STP instruction.
54	COM2	
1 - 21	S7 - S27	Terminals for outputting segment signals to FL display driver IC. A control of a maximum of 54 segments is possible on the basis of matrix with COM1 and COM2. Data are outputted through these terminals when SEG instruction (COM1 system) or MARK instruction (COM2 system) is executed. Note: The output is fixed at "L" level when the system is reset or executing CK STP instruction.
55 - 60	S1 - S6	

•CXP5014 < FL Display Driver >

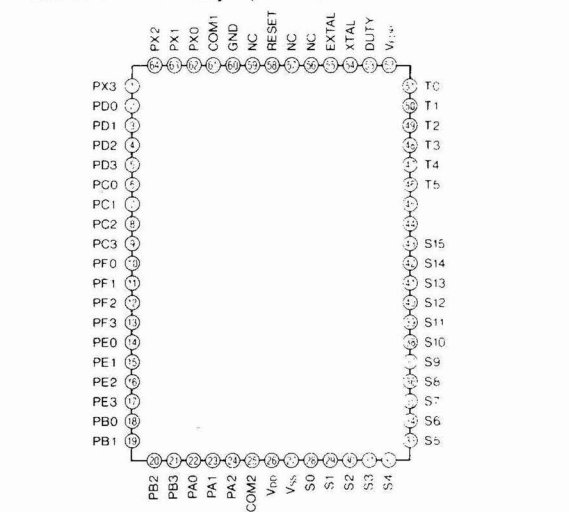

Pin No.	Pin Name	Function
24 - 27	K0 - K3	Ports for inputting a 4-bit key matrix signal. On the other hand, key return timing signals are outputted from output ports T0 to T6.
28 - 34	T0 - T6	Ports for outputting key matrix return timing signals. A 4-bit signal is outputted from T0 to T3, while a 3-bit signal is outputted from T4 to T6.
35	A/D IN	Terminals for inputting analog signals to 4-bit built-in A/D converter. The built-in A/D converter is of successive comparison type in dependence upon program. A reference voltage is inputted through DC-REF and an analog comparison voltage is inputted through A/D IN.
36	DC-REF	
41	MUTE	A port for outputting a mute control signal. Note: This output is set to "L" level automatically when INH input changes from "H" to "L" or vice versa.
42	STB	Serial interfaces for STB (strobe pulse output) LC7217, CK (serial clock output), SO (serial data output), and SI (serial data input). LC7217 PLL IC is controlled by executing SIO instruction.
38	SO	
37	SI	
46	CK	Terminal for outputting a reference frequency signal supplied to LC7217 PLL IC. Note: This output is fixed at "L" level automatically when INH input is at "L" level.
47	INT	Terminal for inputting a system resetting signal to device. When INT is at "L" level, the device is reset; when at "H" level, program starts beginning from address No.0. This terminal is usually fixed at "H" level, because the device is reset when a voltage of 4.5V is applied to V _{res} (power-on reset)
49	TEST	Terminal for inputting a test mode control signal. The device is returned to the ordinary operation at "L" level or in NC status. This terminal includes a pull-down resistor and is fixed at "L" level usually.
50	XT	Terminals for connecting a quartz oscillator of 7.4 MHz.
51	XT	
52	GND	GND Terminal
23	V _{cc}	Terminal for applying a device supply voltage. In the normal operation, a voltage of 5V ± 10% is applied; but in back-up condition, the voltage can be reduced to 2V. Further, when a voltage of 4.5V is applied to this terminal, the device is reset and then program starts beginning from address No.0 (power-on reset).
53	V _{cc}	

♦ CXP5014 < Terminal Function >

Pin No.	Pin Name	i/O	Description
1 - 24	PX3, PD0 - 3, PC0 - 3, PE0 - 3, PA0 - 2, PX0 - 2	i	Terminal for inputting a FL display indicator driving signals.
62 - 64	COM2	i	
25	COM2	i	Terminal for inputting common signal for FL display.
26, 59	V _{cc}	-	Terminals for applying a device supply voltage.
27, 60	GND	-	GND Terminal
28 - 43	S1 - S15	O	Terminals for outputting segment signals to FL display.
46 - 51	T5 - T0	O	Terminals for outputting grid signals to FL display.
S2	V _{cc}	-	Terminal for connecting a supply voltage (-) to filament of FL display.
53	DUTY	i	Terminal for setting a display mode for FL display. Normally this terminal is kept in "L" level.
54, 55	XT, XT	-	Terminal for connecting a quartz oscillator of 3.6 MHz.
58	RESET	-	Terminal for inputting a reset signal.
61	COM1	i	Terminal for inputting common signal for FL display.

SANSUI ELECTRIC CO., LTD.:

SANSUI ELECTRONICS CORPORATION:

SANSUI ELECTRONICS (U.K.) LTD.:
 SANSUI ELECTRONICS G.M.B.H.:

山水電気株式会社

14-1, Izumi 2-chome, Suginami-ku, Tokyo 168 Japan
 PHONE: (03) 324-8891 / TELEX: 232-2076 (International Division)
 1250 Valley Brook Ave. Lyndhurst, N.J. 07071 U.S.A.
 17150 South Margay Ave. Carson, California 90746 U.S.A.
 3036 Koapaka Street, Honolulu, Hawaii 96819 U.S.A.
 Unit 10A, Lyon Industrial Estate, Rockware Avenue, Greenford, Middx UB6, OAA, England
 Paul Ehrlich Strasse 8, 6074 Rödermark 2, West Germany

HE国内営業部 サービス推進部 東京都三鷹市下連雀8-9-16(〒181) 電話0422-46-8131

